



Producent i dystrybutor:
PRODUCENT SŁUPÓW I OPRAW OŚWIETLENIOWYCH
FIRMA PRODUKCYJNO-HANDLOWA ART METAL Sp.j.
83-331 PRZYJAŻŃ, ŁAPINO 34

POLE KT

Construction:

The KT posts are built from 3 steel pipes, each with a different diameter, that overlap one another at a length of approx. 100 mm or 150 mm depending on the diameter of the interconnected pipes; thus forming a telescopic connection.

The pipe diameter becomes narrower towards the top of the post and equals $\varnothing 273$.

At the base, the post is welded to the retaining flange. The structure of the post extends beyond the flange and all the points where the diameter is reduced are masked with decorative cast elements.

The KT post is richly decorated and has a large, decorative aluminium base. The base of the post is fitted with a port that enables access to the inside of the base.

The port has an access door that is closed with the help of a bolt. A mounting rack inside the port enables one to install the connecting panel.

The upper part of the post is a straight pipe cut at an angle of 90° to the axis. Where luminaries are mounted on side-mounted arms rather than at the top of the post, the tip of the post is secured with an aluminium plug. Where an additional arm is to be mounted at the top, the post is fitted with an arm-mounting case.

Anchorage:

The posts should be mounted on foundations that are laid by pouring and have a size dependant on the local soil conditions

TECHNICAL INFORMATION:

Maximum side area mounting on the top of pole are $1,4 \text{ m}^2$
(area simetrically to the pole axis).

Maximum weight on the top of pole **80 kg**.

Parameters calculated for wind area "I" (20m/s) according to PN-77/B-02011

Pole was calculated for additional horizontal force $F=8000\text{N}$ at height $h=4,7\text{m}$ above ground. Different forces can be used past recalculated.

ANCHORAGE:

The posts should be mounted on foundations that are laid by pouring and have a size dependant on the local soil conditions

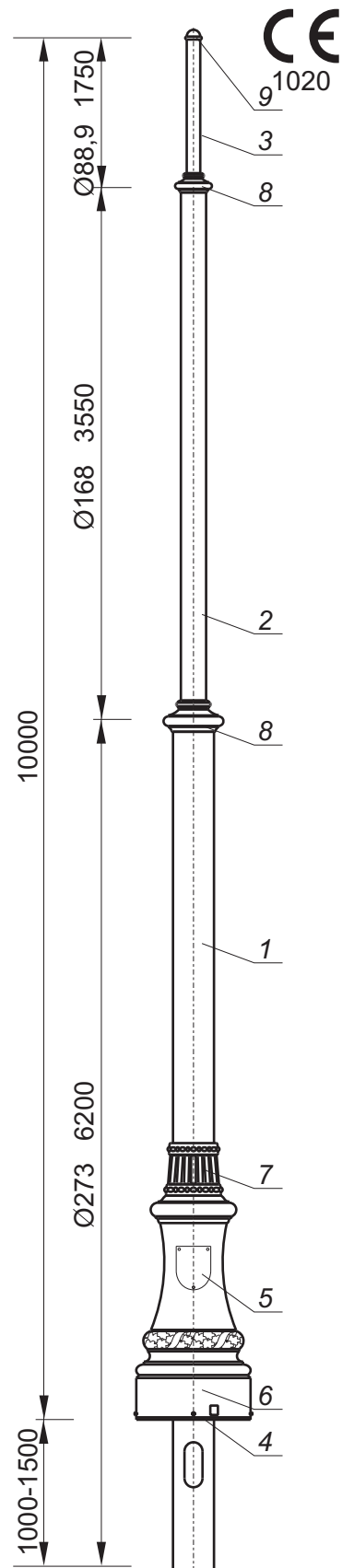

Doc.signature: S-00KT-03

Last revision: 2006.01.31

PRODUCENT SŁUPÓW I OPRAW OŚWIETLENIOWYCH
FIRMA PRODUKCYJNO-HANDLOWA ART METAL Sp.j.
83-331 PRZYJAŻŃ, ŁAPINO 34

TEL.: (+48 58) 681 80 78

<http://www.art-metal.pl>

FAX: (+48 58) 681 80 64

e-mail: biuro@art-metal.pl